

穩定的動力輸出，持續不間斷的輸出壓力，
正確選用的噴槍/噴嘴，最佳的工作效率。

Stable Power Output , Continuous Output Pressure ,
Correct Spray Jet or Nozzle , Best Working Efficiency.



動力噴霧機
Power Sprayer

■ 動力噴霧機 POWER SPRAYER

可選擇處理部份目標範圍，經由便利的壓力及霧化控制，機器可直接針對需要的範圍作處理，避免不必要的浪費和保護植物及農作物不受傷害。可搭配20-35c. c. 引擎的背負式噴霧機，簡便的壓力調整裝置，準確的達到工作所需的壓力。高抗壓力，即使面對受限制或惡劣的工作條件，都能符合操作者最佳的需求。

Ideal for targeted and selective treatments: thanks to the convenient pressure and atomization controls, the machine can direct the spray just where it is needed, avoiding unnecessary waste and ensuring plants and crops are not damaged. The knapsack power sprayer which can be assembled with 20-35 c.c. engines equip with a convenient knob to precisely match the flow pressure to the type of use. High resistance to stress, even when working lengthy stints and operating in hostile conditions: the perfect machine for the most demanding operator.

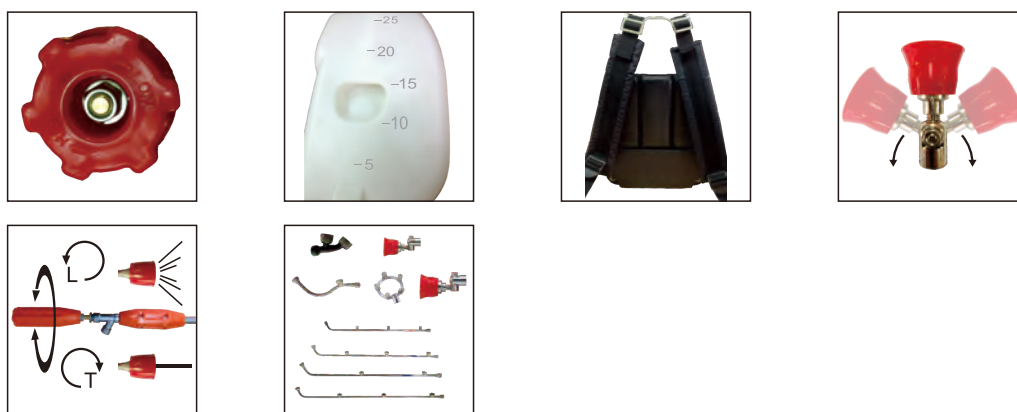

※泵浦搭配鍍鉻活塞提供很好的耐磨性並延長使用壽命。

The pump with chrome piston offer excellent wear-resisting and extended service life.

※泵浦附有簡易調節旋鈕，可精確調整壓力至合適需求，最大操作壓力為35 Kg/cm³。

The pump features a convenient knob allows accurate pressure regulation to suit desired use. The maximum operating pressure is 35 Kg/cm³.

※全系列水桶均使用添加抗UV材料的高張力塑膠材料吹塑成形，並註記水量(公升)。

Whole series Tanks are blow molding by high tension plastic material which add UV inhibitors, and are marked in liters.

※背架上裝設柔軟及勻稱的背墊，背帶使用透氣材料。

Frame with soft, generously proportioned cushion; broad straps in breathable material.

※供應各式噴嘴，依不同覆蓋範圍來搭配各種噴槍。

Wide range of nozzles available with multiple jets for wider coverage.

※可手動調整噴出液方向。(FT-305、FT-306)

Handy manual adjustment of spray droplet direction. (FT-305、FT-306)

※可手動調整噴出液噴灑方式，從一直線到扇型。(FT-101、FT-102、FT-103、FT-104、FT-109)

Handy manual adjustment of spray droplet sprinkling way from a jet to sector. (FT-101、FT-102、FT-103、FT-104、FT-109)

※供應各式1~5孔噴射器的噴槍，可依不同作物表面區域及霧化程度或壓力來選擇適合的噴槍。

Broad choice of jets with from 1 to 5 holes for differentiated treatments on large surface area crops or in situations in which different atomization levels or pressures are required.

■ 泵浦規格 PUMP SPECIFICATION

銅泵 BRASS PUMP

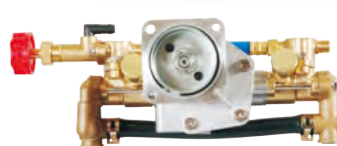
 Clutch Case Φ 88/78 mm

 Clutch Case Φ 66/54 mm

泵浦型號	Pump Model	FTC-16	
泵浦形式	Pump Type	雙向 / 2-Way	
柱塞直徑/行程	Plunger Dia/Stroke	Φ 16mm / 9mm	
泵浦減速比	Pump Reduction Ratio	48:13	
最大壓力	Ma . Pressure	35 kg / cm ² (497.8psi)	
最大吐油量	Max. Delivery Rate	8 Liter / Min	

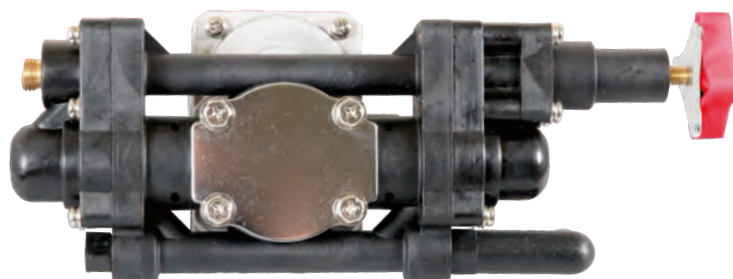
塑泵 PLASTIC PUMP

 Clutch Case Φ 88/78 mm

 Clutch Case Φ 66/54 mm

泵浦型號	Pump Model	FTP-21	FTP-23
泵浦形式	Pump Type	雙向 / 2-Way	
柱塞直徑/行程	Plunger Dia/Stroke	Φ 21mm / 6mm	Φ 23mm / 6mm
泵浦減速比	Pump Reduction Ratio	47:13	
最大壓力	Max. Pressure	30 kg / cm ² (426.7psi)	40 kg / cm ² (568.93psi)
最大吐油量	Max. Delivery Rate	8 Liter / Min	14 Liter / Min

■ 背負式動力噴霧機 KNAPSACK POWER SPRAYER

HT-708 KNAPSACK POWER SPRAYER



水桶型號	Liquid Tank Model	HT-708	
水桶容量	Liquid Tank Cap.	20 公升 / Liter	
可搭配引擎	Fitting Engine	HF-26L	HT-328L
排氣量/功率	Displacement/Power	25.4 c.c. / 0.87kw	30.5 c.c. / 1.7HP
油箱容量	Fuel Tank Cap.	0.7 公升 / Liter	

HT-747 KNAPSACK POWER SPRAYER



水桶型號	Liquid Tank Model	HT-747	
水桶容量	Liquid Tank Cap.	25 公升 / Liter (MAX 27L)	
可搭配引擎	Fitting Engine	HF-26L	HT-328L
排氣量/功率	Displacement/Power	25.4 c.c. / 0.87kw	30.5 c.c. / 1.7HP
油箱容量	Fuel Tank Cap.	0.7 公升 / Liter	

A-引擎 ENGINE



B-泵浦 PUMP



標準配件 STANDARD ACCESSORIES



高壓管
High Pressure Hose



握把式過濾管
Filter Handle



活動頭
Roller



球開關
Ball Cock



2 孔扇形噴嘴
2-HOLE SPRAY NOZZLE



白鐵直管 Stainless Spray Rod

■ 背負式動力噴霧機 KNAPSACK POWER SPRAYER

HT-767/768 KNAPSACK POWER SPRAYER



水桶型號	Liquid Tank Model	HT-767		HT-768	
水桶容量	Liquid Tank Cap.	30 公升 / Liter		25 公升 / Liter	
可搭配引擎	Fitting Engine	HF-26LT	HT-328LT	GX-25	GX-35
排氣量/功率	Displacement/Power	25.4 c.c. / 0.87kw	30.5 c.c. / 1.7HP	25 c.c. / 1.0HP	35.8 c.c. / 1.4HP
油箱容量	Fuel Tank Cap.	0.87 公升 / Liter	1 公升 / Liter	0.58 公升 / Liter	0.63 公升 / Liter
機油箱容量	Oil Tank Capacity			0.08 公升 / Liter	0.1 公升 / Liter

A-引擎 ENGINE



POWERED by
HONDA™

B-泵浦 PUMP



FTC-16

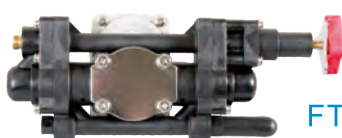

FTP-21

標準配件 STANDARD ACCESSORIES



高壓管
High Pressure Hose



握把式過濾管
Filter Handle



活動頭
Roller



球開關
Ball Cock



2 孔扇形噴嘴
2-HOLE SPRAY NOZZLE



白鐵直管 Stainless Spray Rod

■ 手推引擎噴霧機 HAND PUSH ENGINE SPRAYER

HPGS-50B HAND PUSH ENGINE SPRAYER



HPGS-50B

水桶型號	Liquid Tank Model	HPGS-50B				
水桶容量	Liquid Tank Cap.	50 公升/Liter(MAX 50L)				
可搭配引擎	Fitting Engine	HF-26LT	HT-328LT	TB-33L	GX-25	GX-35
排氣量/功率	Displacement/Power	25.4 c.c. / 0.87kw	30.5 c.c. / 1.7HP	32.6 c.c. / 1.7HP	25 c.c. / 1.0HP	35.8 c.c. / 1.4HP
油箱容量	Fuel Tank Cap.	0.87 公升 / Liter	1 公升 / Liter	1 公升 / Liter	0.58 公升 / Liter	0.63 公升 / Liter
機油箱容量	Oil Tank Capacity				0.08 公升 / Liter	0.1 公升 / Liter

A-引擎 ENGINE



B-泵浦 PUMP



FTC-16

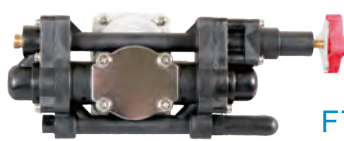

FTP-21/FTP-23

■ 手推式電動噴霧機 HAND PUSH ELECTRIC SPRAYER

HPES-50B HAND PUSH ELECTRIC SPRAYER



型號	Model	HPES-50B
藥桶容量	Liquid Tank Cap.	50 公升 / Liter(MAX 50L)
泵浦形式	Pump Type	雙隔膜泵浦 / Diaphragm pump Double
出水量	Max. Flow Rate	1~8 升 / 1~8 L/min
作業壓力	Max. Pressure	0.15-0.8 MPA
蓄電池	Battery	12 V-12 Ah
充電時間	Charge Time	4小時(首次8~10小時) / 4 hrs (First Time 8~10 hrs)
連續作業時間	Activity duration	2~6小時 / 2~6 hrs

■ 噴霧車 SPRAYER CART

HPS-50II / III HYBRID PUSH SPRAYER



※ 噴桿可依需求訂製
標配噴桿左右總長4.5M / 16孔噴嘴
Standard Rod : Total Length 4.5M WITH 16 NOZZLES

EDS-100/150 ELECTRIC DRIVING SPRAYER



※ 噴桿可依需求訂製
標配噴桿高度1.8米*8孔噴嘴*2支
Standard Rod: 1.8M ROD WITH 8 NOZZLES * 2



型號	Model	HDS-50II	HDS-50III	EDS-100	EDS-150
形式	Type	二輪手推 HAND PUSH TWO WHEEL	三輪手推 HAND PUSH THREE WHEEL	四輪駕駛 DRIVING FOUR WHEEL	
料桶/水桶容量	Tank Capacity	50 公升 / Liter	50 公升 / Liter	100 公升 / Liter	150 公升 / Liter
馬達功率	Motor Power	350W	350W	500W	600W
引擎型號	Engine Model	TB-33L			
行走速度*	Working Speed	手推 MANUAL		0 - 6.3 km/h	
行駛時間*(滿電半載測試)	Working Time	連續4小時 / Continuously Working 4 hrs		連續2小時 / Continuously Working 2 hrs	
電池規格	Battery	12V x 24Ah x 2		12V x 50Ah x 2	
充電時間(完全無電)	Charging Time	6 小時 / hrs		8 小時 / hrs	
機台尺寸	Machine Size	130 x 55 x 110cm		120 x 58 x 194cm	120 x 58 x 194cm
輪胎尺寸	Ttre Size	前輪寬 FRONT WHEEL WIDTH 8cm 後輪寬 BACK WHEEL WIDTH 14cm	前輪寬 FRONT WHEEL WIDTH 5cm 後輪寬 BACK WHEEL WIDTH 11cm*2	前輪寬 FRONT WHEEL WIDTH 3.5-4cm 後輪寬 BACK WHEEL WIDTH 3.5-6cm	

■ 自走式施肥機/電動收管機 HAND PUSH FERTILIZER SPREADER

HPFS-43 自走式施肥機 HAND PUSH FERTILIZER SPREADER



型號	Model	HPFS-43
形式	Type	二輪手推
料桶/水桶容量	Tank Capacity	43 公升 / Liter
引擎型號	Engine Model	TB-43L
行走速度 *	Working Speed	手推 MANUAL
機台尺寸	Machine Size	54 x 89 x 120cm
輪胎尺寸	Tyre Size	大輪寬 14cm 小輪寬 8cm

EHC-12 電動收管機 ELECTRIC HOSE COLLECTOR



型號	Model	EHC-12
馬達功率	Motor Power	12V x 350W
適收管徑	For Hose ID	7.5 / 8.5 / 10
機台尺寸	Machine Size	20 x 21 x 60.5cm

■ 電動噴霧機 ELECTRIC SPRAYER

KES-16LH/20LH/16LI/20LI KNAPSACK ELECTRIC SPRAYER



型號	Model	KES-16LI	KES-20LI	KES-16LH	KES-20LH
藥桶容量	Liquid Tank Cap.	16 公升 / Liter(MAX 16L)	20 公升 / Liter(MAX 20L)	16 公升 / Liter(MAX 16L)	20 公升 / Liter(MAX 20L)
泵浦形式	Pump Type	隔膜泵浦 / Diaphragm pump			
出水量	Max. Flow Rate	0.9~3.0 L/min		1.0~3.5 L/min	
作業壓力	Max. Pressure	0.15~0.4MPA		0.15~0.6MPA	
蓄電池	Battery			12V-12Ah	
鋰電池	Li-Battery	12V-12Ah			
充電時間	Charge Time	4小時(首次8~10小時) / 4 hrs (First Time 8~10 hrs)			
連續作業時間	Activity duration	5~6 小時 / 5~6 hrs			

標準配件 STANDARD ACCESSORIES



單孔噴頭(S)
Single Hole Spray
Nozzle (S)



單孔噴頭(E)
Single Hole Spray
Nozzle (E)



雙孔噴頭
2 Hole Spray Nozzle



6孔噴頭(大)
6 Holes Spray Nozzle



伸縮噴桿
Extension Spray Rod

■ 電動噴霧機 ELECTRIC SPRAYER

KES-05/08/10 ELECTRIC SPRAYER



SWITCHABLE BATTERY

型號	Model	KES-05	KES-08	KES-10
藥桶容量	Liquid Tank Cap.	5 公升 / Liter	8 公升 / Liter	10 公升 / Liter
泵浦形式	Pump Type	隔膜泵浦 / Diaphragm pump		
出水量	Flow Rate	0.6~1.5 L/min		
鋰電池	Li-Battery	3.6V 18650*3		
充電時間	Charge Time	3小時 (首次8~10小時) / 3 hrs (First Time 8~10 hrs)		
連續作業時間	Activity duration	3小時 / 3 hrs		

GES-01/02 GARDEN ELECTRIC SPRAYER



GES-01

GES-02

型號	Model	GES-01	GES-02
藥桶容量	Liquid Tank Cap.	2 公升 / Liter	
出水量	Flow Rate	0.25-0.6 L/min	
鋰電池	Li-Battery	3, 6V 18650*1	
充電時間	Charge Time	2 小時 / 2 hrs	
連續作業時間	Activity duration	每次連續7分鐘/總作業時間2小時 7min/each, total working time 2 hrs	

■ 手提式噴霧機 PORTABLE SPRAYER

PS-16/21 PORTABLE SPRAYER



型號	Model	PS-16		PS-21		PS-23	
泵浦	Pump	FTC-16		FTP-21		FTP-23	
可搭配引擎	Fitting Engine	HF-26LT	HT-328LT	GX-25	GX-35	GX-50	
排氣量/功率	Displacement/Power	25.4 c.c. / 0.87kw	30.5 c.c. / 1.7HP	25 c.c. / 1.0HP	35.8 c.c. / 1.4HP	47.9 c.c. / 2.0HP	
油箱容量	Fuel Tank Cap.	0.87 公升 / Liter	1 公升 / Liter	0.58 公升 / Liter	0.63 公升 / Liter	0.63 公升 / Liter	
機油箱容量	Oil Tank Capacity			0.08 公升 / Liter	0.1 公升 / Liter	0.13 公升 / Liter	

A-引擎 ENGINE



B-泵浦 PUMP

POWERED by
HONDA™



FTC-16

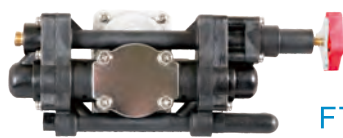

FTP-21/FTP-23

標準配件 STANDARD ACCESSORIES



2.4M 吸水管 Suction Pipe

2.4M 迴水管 Overflow Pipe

1/2" 不鏽鋼濾網 Stainless Filter

■ 定置式噴霧機 STATIONARY PLUNGER SPRAYER

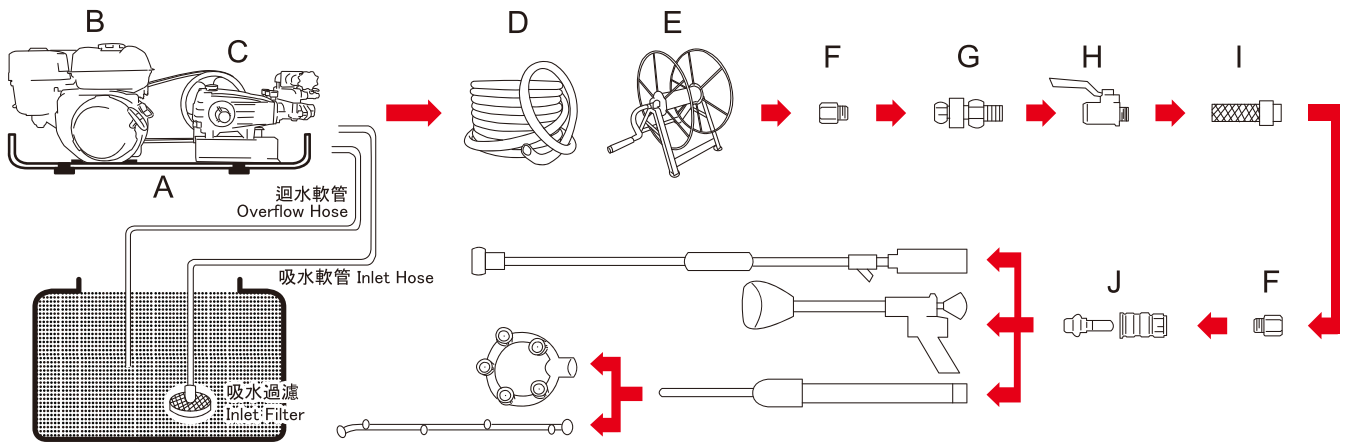

A-定置式架/皮帶輪 STATIONARY SPRAYER FRAME/BELT PULLEY

請參考P44 • Please refer Page 44.

B-引擎/馬達 ENGINE/MOTOR

請參考P46 • Please refer Page 46.

C-柱塞泵浦 PLUNGER PUMP

請參考P47-51 • Please refer Page 47-51.

D-高壓管 SPRAY HOSE

請參考P44-45 • Please refer Page 44-45.

E-高壓管架 SPRAYER HOSE FRAME

請參考P44 • Please refer Page 44.

F-接頭 SPRAYER HOSE CONNECTOR

請參考P52 • Please refer Page 52.

G-活動頭 SWIVEL CONNECTOR

請參考P53 • Please refer Page 53.

H-球開關 BALL COCK

請參考P52 • Please refer Page 52.

I-過濾管 FILTER

請參考P54 • Please refer Page 54.

J-快速接頭 QUICK CONNECT

請參考P53 • Please refer Page 53.

K-各式噴霧用件 Spary Accessories

請參考P55-67 • Please refer Page 55-67.

■ 定置式腳架/皮帶輪/高壓管/高壓管架 STATIONARY SPRAYER FRAME/BELT PULLEY/ SPRAYER HOSE/SPRAYER HOSE FRAME

定置式腳架/皮帶輪 STATIONARY SPRAYER FRAME/BELT PULLEY



SSF-1F

SSF-1B

型號 Model	SSF-1F	SSF-1B
品名 Product Name	1吋平架 1" Flate Frame	1吋巴士架 1" Bus Frame
尺寸 Size L*W*H(cm)	85*31*10.5	86*34*43

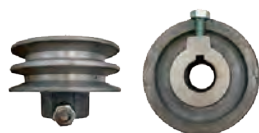

型號 Model	BP-20C-XX	BP-25C/A-XX	BP-30C/A-XX	BP-35C/A-XX	BP-40C-XX
品名 Product Name	皮帶輪				
材質 Material	鑄鐵	鑄鐵/鋁		鑄鐵	
外徑 Out Diameter	2吋/inch	2吋/inch	3吋/inch	3.5吋/inch	4吋/inch
孔徑 Inner Diameter	Ø18 / 19 / 20 / 22 / 24 / 25 / 28 / 32mm				

※XX代表孔徑，18代表18mm，20代表20mm，以此類推。

XX means Inner Diameter. 18 means 18mm, and 20 means 20mm, and so on.

高壓管 SPRAYER HOSE

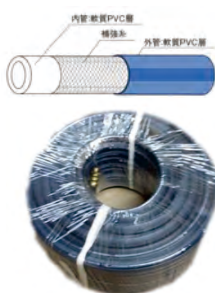

型號 Model	SH-075-XX	SH-085-XX	SH-100-XX	SH-130-XX
內孔徑 I.D.	Ø7.5mm	Ø8.5mm	Ø10mm	Ø13mm
接頭 Connector	SW13.8 / G(PF)1/4"		G(PF)3/8"	G(PF)1/2"
工作壓力 Working Pressure	50kg/cm ²			
爆破壓力 Burst Pressure	250kg/cm ²			
長度 Length	10 / 20 / 30 / 50 / 60 / 100 / 150 / 200M			

※XX代表長度，05代表50米，10代表100米，15代表150米，以此類推。

XX means Length. 05 means 50 meters, and 10 means 100 meters, and so on.

高壓管架 SPRAYER HOSE FRAME



型號 Model	SHF-50	SHF-100(B)	SHF-150(B)	SHF-200(B)
適用管長 Hose Length	50M	100M	150M	200M
適用內管徑 For Hose ID.	Ø7.5/8.5/10/13mm		Ø7.5/8.5mm	

※(B)代表軸承版。